

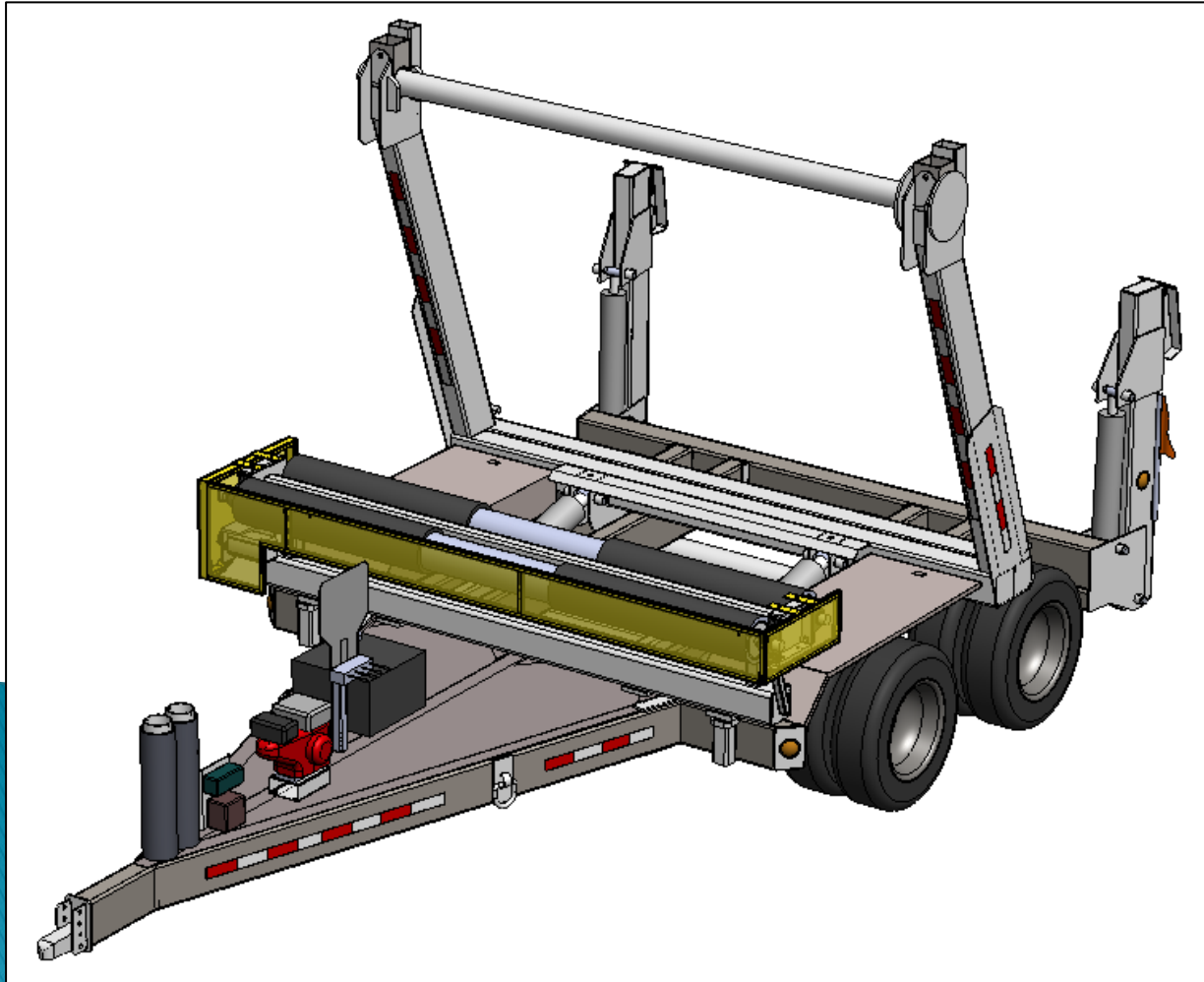

Phone: (403) 851 1900
E-mail: info@flexreeltrailers.com

FR-40 Series Self loading reel trailer with re-spooler



FR-40 Series Self loading reel trailer with re-spooler

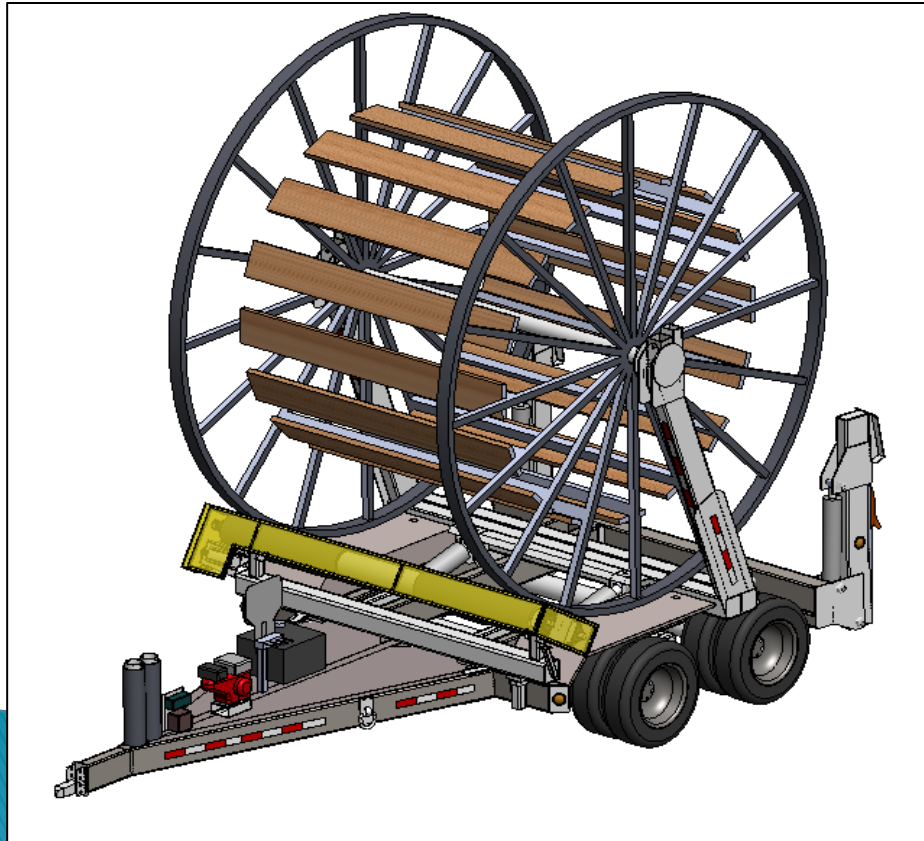

- ❑ Powered by 13 HP Honda hydraulic power unit with Electric Start
- ❑ Handles single 8 Ft. wide or 2-4 Ft. wide X12 Ft. diameter Reels
- ❑ Ideal for stringing or re-spooling continuous lengths of flexible pipe

FR-40 Series Self loading reel trailer with re-spooler



- Durable and proven design
- Reliable and low maintenance
- Safest way to handle large reels

FR-40 Series loading a reel in the staging area



- Outriggers extend to stabilize the trailer
- Safely load reels weighing up to 13,000lbs (5900kg)
- Simple to operate



Phone: (403) 851 1900
E-mail: info@flexreeltrailers.com

FR-40 Series trailer stringing pipe





Phone: (403) 851 1900
E-mail: info@flexreeltrailers.com

FR-40 Series trailer loaded for long haul transport





Phone: (403) 851 1900
E-mail: info@flexreeltrailers.com

FR-40 Series specifications

Trailer specifications	Metric	Imperial
Trailer Weight (without load)	2,700 Kg	6,000 lbs
Re-spooler weight	385 kg	850 lbs
Height (without reel)	3.05 m	10 ft
Height (with 12 ft diameter reel)	4.42 m	14.5 ft
Width (standard)	2.90 m	9 ft – 6 in
Width (with re-spooler)	3.05 m	10 ft
Length	5.80 m	19 ft
Gross Axel Weight Rating (per axle)	4,536 kg	10,000 lbs
Gross Axel Weight Rating (total)	9,072 kg	20,000 lbs
Maximum Reel Weight	5,900 kg	13,000 lbs
Maximum Reel Diameter	3.66 m	12 ft
Maximum Reel Width	2.44 m	8 ft
Maximum Transport Speed (without reel)	100 km/hr	60 mph
Maximum Transport Speed (with reel)	50 km/hr	30 mph